

OWNER'S MANUAL



MODEL: PB1600P51
PART: 10804



PIT BOSS[®] PRO SERIES

WOOD PELLET GRILL & SMOKER

IMPORTANT, READ CAREFULLY, RETAIN FOR FUTURE REFERENCE. MANUAL MUST BE READ BEFORE OPERATING!



WARNING: PLEASE READ THE ENTIRE MANUAL BEFORE INSTALLATION AND USE OF THIS ELECTRIC, PELLET FUEL-BURNING APPLIANCE. FAILURE TO FOLLOW THESE INSTRUCTIONS COULD RESULT IN PROPERTY DAMAGE, BODILY INJURY OR EVEN DEATH. CONTACT LOCAL BUILDING OR FIRE OFFICIALS ABOUT RESTRICTIONS AND INSTALLATION INSPECTION REQUIREMENTS IN YOUR AREA.



SMOKE IT[®]

For outdoor and household use only. Not for commercial use.

SAFETY INFORMATION

MAJOR CAUSES OF APPLIANCE FIRES ARE A RESULT OF POOR MAINTENANCE AND A FAILURE TO MAINTAIN REQUIRED CLEARANCE TO COMBUSTIBLE MATERIALS. IT IS OF UTMOST IMPORTANCE THAT THIS PRODUCT BE USED ONLY IN ACCORDANCE WITH THE FOLLOWING INSTRUCTIONS.

Please read and understand this entire manual before attempting to assemble, operate or install the product. This will ensure you receive the most enjoyable and trouble-free operation of your new wood pellet grill. We also advise you retain this manual for future reference.

DANGERS AND WARNINGS

You must contact your local home association, building or fire officials, or authority having jurisdiction, to obtain the necessary permits, mission or information on any installation restrictions, such as any grill being installed on a combustible surface, inspection requirements or even ability to use, in your area.

1. A minimum clearance of 914 mm (36 inches) from combustible constructions to the sides of the grill, and 914 mm (36 inches) from the back of the grill to combustible constructions must be maintained. **Do not install appliance on combustible floors, or floors protected with combustible surfaces unless proper permits and permissions are obtained by authorities having jurisdiction.** Do not use this appliance indoors, in an enclosed or unventilated area, inside homes, vehicles, tents, garages. This wood pellet appliance must not be placed under overhead combustible ceiling or overhang. Keep your grill in an area clear and free from combustible materials, gasoline and other flammable vapors and liquids.

Should a grease fire occur, turn the grill OFF and leave the lid closed until the fire is out. Unplug the power cord. Do not throw water on the unit. Do not try to smother the fire. Use of an all-class (class ABC) approved fire extinguisher is valuable to keep on site. If an uncontrolled fire does occur, call the Fire Department.

2. Keep electrical supply cords and the fuel away from heated surfaces. Do not use your grill in the rain or around any water source. If the supply cord is damaged, it must be replaced by the manufacturer, its service agent or similarly qualified persons in order to avoid a hazard.
3. After a period of storage, or non-use, check the Burn Pot for obstructions, the hopper for foreign objects, and any air blockage around the fan intake or chimney. Clean before use. Regular care and maintenance is required to prolong the lifespan of your unit. **If the grill is stored outside during the rainy season or seasons of high humidity, care should be taken to insure that water does not get into the hopper.** When wet or exposed to high humidity, wood pellets will expand greatly, decompose, and may jam the feed system. Always disconnect the power, before performing any service or maintenance.

Do not transport your grill while in use or while the grill is hot. Ensure the fire is completely out and that the grill is completely cool to the touch before moving.

4. It is recommended to use heat-resistant barbecue mitts or gloves when operating the grill. Do not use accessories not specified for use with this appliance. Do not put a barbecue cover or anything flammable in the storage space area under the barbecue.

- To prevent fingers, clothing or other objects from coming in contact with the auger feed system, the appliance is equipped with a metal safety screen, mounted to the interior of the hopper. This screen must not be removed unless directed by Customer Service or an authorized dealer.

This appliance can be used by children aged from 8 years and above and persons with reduced physical, sensory or mental capabilities or lack of experience and knowledge if they have been given supervision or instruction concerning use of the appliance in a safe way and understand the hazards involved. Children shall not play with the appliance. Cleaning and user maintenance shall not be made by children without supervision.

- Parts of the barbecue may be very hot, and serious injury may occur. Keep young children and pets away while in use.
- Do not enlarge ignitor holes or Burn Pots. Failure to follow this warning could lead to a fire hazard and bodily harm and will void your warranty.
- Product may have sharp edges or points. Contact may result in injury. Handle with care.

DISPOSAL OF ASHES

Ashes should be placed in a metal container with a tight-fitting lid. The closed container of ashes should be placed on a non-combustible floor or on the ground, well away from all combustible materials, pending final disposal. When ashes are disposed by burial in soil, or otherwise locally dispersed, they should be retained in a closed container until all cinders have thoroughly cooled.

WOOD PELLET FUEL

This pellet cooking appliance is designed and approved for pelletized, all natural, wood fuel only. Any other type of fuel burned in this appliance will void the warranty and safety listing. You must only use all natural wood pellets, designed for burning in pellet barbecue grills. Do not use fuel with additives. Wood pellets are highly susceptible to moisture and should always be stored in an airtight container. If you are storing your grill, without use, for an extended period, we recommend clearing all pellets from your grill's hopper and auger, to prevent jams. The pellet fuel mean heating value in 8000-8770 BTU/LB, ash content < 1%.

Do not use spirit, petrol, gasoline, lighter-fluid or kerosene for lighting or refreshing a fire in your grill. Keep all such liquids well away from the appliance when in use.

At the time of printing, there is no industry standard for barbecue wood pellets, although most pellet mills use the same standards to make wood pellets for domestic use. Further information, can be found at www.pelletheat.org or the **Pellet Fuel Institute**.

Contact your local dealer on the quality of pellets in your area, and for information on brand quality. As there is no control over the quality of pellets used, moisture affected pellets, we assume no responsibility to damage caused by poor quality of fuel.

CREOSOTE

Creosote, or soot, is a tar-like substance. When burning, it produces black smoke with a residue which is also black in color. Soot or creosote is formed when the appliance is operated incorrectly, such as: blockage of the combustion fan, failure to clean and maintain the burn area, or poor air-to-fuel combustion.

It is dangerous to operate this appliance should the flame become dark, sooty, or if the Burn Pot is overfilled with pellets. When ignited, this creosote makes an extremely hot and uncontrolled fire, similar to a grease fire. Should this happen, turn the unit OFF, let it cool completely, then inspect for maintenance and cleaning. It commonly accumulates along exhaust areas.

If creosote has formed within the unit; allow the unit to warm up at a low temperature, turn off the appliance, then wipe away any formation with a hand towel. Similar to tar, it is much easier to clean when warm, as it becomes liquid.

CARBON MONOXIDE (“THE SILENT KILLER”)

Carbon monoxide is a colorless, odorless, tasteless gas produced by burning gas, wood, propane, charcoal or other fuel. Carbon monoxide reduces the blood’s ability to carry oxygen. Low blood oxygen levels can result in headaches, dizziness, weakness, nausea, vomiting, sleepiness, confusion, loss of consciousness or death. Follow these guidelines to prevent this colorless, odorless gas from poisoning you, your family, or others:

- See a doctor if you or others develop cold or flu-like symptoms while cooking or in the vicinity of the appliance. Carbon monoxide poisoning, which can easily be mistaken for a cold or flu, is often detected too late.
- Alcohol consumption and drug use increase the effects of carbon monoxide poisoning.

Carbon monoxide is especially toxic to mother and child during pregnancy, infants, the elderly, smokers, and people with blood or circulatory system problems, such as anemia, or heart disease.

SAFETY LISTING

Conforms to EN 60335-2-102:2016, EN 60335-1:2012 + A11:2014 + A13:2017 + A1: 2019 + A14: 2019 + A2: 2019, EN62233: 2008, EN 55014-1:2017, EN IEC 61000-3-2:2019, EN 61000-3-3:2013+A1:2019, EN 55014-2:2015.



FCC COMPLIANCE STATEMENT

This device complies with Part 15 of FCC Rules. Operation is subject to the following two conditions: (1) This device may not cause harmful interference, and (2) This device must accept any interference received, including interference that may cause undesired operation.



This equipment has been tested and found to comply with the limits for a Class B digital device, pursuant to part 15 of FCC Rules. These limits are designed to provide reasonable protection against harmful interference in a residential installation. This equipment generates, uses, and can radiate radio frequency energy and, if not installed and used in accordance with the instructions, may cause harmful interference to radio communications. However, there is no guarantee that interference will not occur in a particular installation. If this equipment does cause harmful interference to radio or television reception, which can be determined by turning the equipment off and on, the user is encouraged to try to correct the interference by one or more of the following measures:

- Reorient or relocate the receiving antenna.
- Increase the separation between the equipment and receiver.
- Connect the equipment into an outlet on a circuit different from that to which the receiver is connected.
- Consult the dealer or an experienced radio/TV technician for help.

Caution: The user is cautioned that changes or modifications not expressly approved by the party responsible for compliance could void the user’s authority to operate the equipment.

The Bluetooth® word mark and logo are registered trademarks owned by Bluetooth® SIG, Inc. and any use of such marks by Espressif is under license. Other trademarks and tradenames are those of their respective owners.



COPYRIGHT NOTICE

Copyright 2021. All right reserved. No part of this manual may be copied, transmitted, transcribed, stored in a retrieval system, in any form or by any means without expressed written permission of,

Dansons

3411 North 5th Avenue, Suite 500, Phoenix, AZ, USA 85013
sales@pitboss-grills.com | service@pitboss-grills.com
www.pitboss-grills.com

Customer Service

Monday through Sunday, 4am - 8pm PST (EN/FR/ES)
Toll-Free: 1-877-303-3134, Fax: 1-877-303-3135

TABLE OF CONTENTS

- Safety Information 2
- Parts & Specs..... 6
- Assembly Preparation..... 7
- Assembly Instructions
 - Mounting The Legs To Main Barrel 7
 - Installing The Bottom Shelf 8
 - Adding Wheels To The Cart 8
 - Installing The Lid Handle 8
 - Assembling The Side Shelf 9
 - Mounting The Side Shelf 9
 - Securing The Chimney 9
 - Securing The Front Shelf Brackets..... 10
 - Installing The Front Shelf 10
 - Placing The Diffuser Plate..... 10
 - Installing The Flame Broiler Components 11
 - Installing The Cooking Components 12
 - Mounting The Rack Hanger 12
 - Placing The Grease Bucket 12
 - Installing The Power Cord 13
 - Connecting To A Power Source..... 13
- Operating Instructions
 - Grill Environment 14
 - Grill Temperature Ranges 15
 - Understanding The Control Board 16
 - Control Board Functions 18
 - Connecting To The Smoke iT® App 19
 - Hopper Priming Procedure 20
 - First Use – Grill Burn-Off 20
 - Automatic Start-Up Procedure..... 20
 - Shutting Off Your Grill..... 20
- Care & Maintenance 21
- Tips & Techniques 23
- Troubleshooting 24
- Electrical Wire Diagram 26
- Replacement Parts
 - Grill Replacement Parts 27
 - Hopper Replacement Parts..... 28
- Warranty 29

PARTS & SPECS

Part#	Description
1	Top Cooking Rack (x1)
2	Middle Cooking Rack (x1)
3	Griddle (x1)
4	Cooking Grids (x4)
5	Flame Broiler Slider (x1)
6	Flame Broiler Main Plate (x1)
7	Chimney Gasket (x1)
8	Chimney Cap (x1)
9	Chimney Stack (x1)
10	Rack Hanger (x1)
11	Lid Handle (x1)
12	Main Barrel / Hopper Assembly (x1)
13	Flame Broiler Adjusting Bar Handle (x1)
14	Flame Broiler Adjusting Bar (x1)
15	Meat Probe (x2)
16	Grease Bucket (x1)
17	Side Shelf (x1)
18	Diffuser Plate (x1)
19	Front Shelf Bracket / Left (x1)
20	Front Shelf Bracket / Right (x1)
21	Front Shelf (x1)
22	Left Support Leg - Front (x1)
23	Left Support Leg - Back (x1)
24	Right Support Leg - Front (x1)
25	Right Support Leg - Back (x1)
26	Bottom Shelf (x1)
27	Locking Caster Wheels (x2)
28	Wheel (x2)
29	Power Cord Clip (x1)
30	Power Cord - F Plug (x1)
31	Power Cord - G Plug (x1)
A	Screw (x28)
B	Washer (x24)
C	Locking Washer (x22)
D	Tool Hook (x3)
E	Wheel Cotter Pin (x2)
F	Wheel Washer (x2)
G	Wheel Axle Pin (x2)
H	Screw (x2)
I	Nut (x2)
J	Bushing (x2)

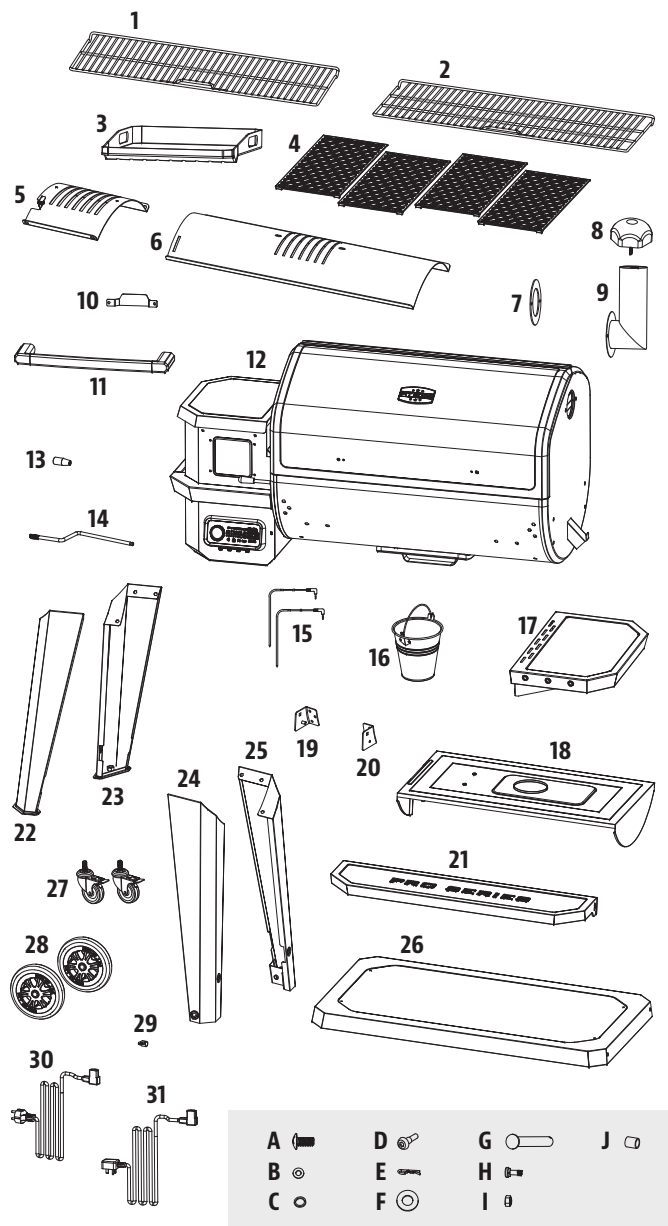

NOTE: Due to ongoing product development, parts are subject to change without notice. Contact Customer Service if parts are missing when assembling the unit.

PB – ELECTRIC REQUIREMENTS
220-240 V, 50 Hz, 275 W, 3-PRONG GROUNDED PLUG

MODEL	ASSEMBLED (WxDxH)	WEIGHT	COOKING AREA	TEMPERATURE RANGE
PB PB1600PS1	1,587.5 MM x 813.5 MM x 1,400 MM / 62.50 IN. x 32.03 IN. x 55.12 IN.	110.0 KG / 242.5 LB	TOP RACK - 2,474.8 CM ² / 383.6 IN ² MIDDLE - 3,249.6 CM ² / 503.7 IN ² MAIN - 4,587.1 CM ² / 711.0 IN ² TOTAL - 10,311.5 CM ² / 1,598.3 IN ²	82-260°C / 180-500°F

ASSEMBLY PREPARATION

Parts are located throughout the shipping carton, including underneath the grill. Inspect the grill, parts, and hardware blister pack after removing from the protective shipping carton. Discard all packaging materials from inside and outside of the grill before assembly, then review and inspect all parts by referencing the parts list. If any part is missing or damaged, do not attempt to assemble. Shipping damage is not covered under warranty. Contact your dealer or Pit Boss® Customer Service for parts: Monday through Sunday, 4am - 8pm PST (EN/FR/ES).

service@pitboss-grills.com | Toll-Free: 1-877-303-3134 | Toll-Free Fax: 1-877-303-3135

IMPORTANT: To ease installation, using two people is helpful (but not necessary) when assembling this unit.

Tools required for assembly: screwdriver and level. *Tools not included.*



ASSEMBLY INSTRUCTIONS

IMPORTANT: It is advised to read each step entirely before starting assembly on instructions. Do not tighten screws completely until all screws for that step have been installed. Hardware combination involving a locking washer and washer should be installed with the locking washer closest to the head of the screw.

1. MOUNTING THE LEGS TO THE MAIN BARREL

Parts Required:

- 1 x Main Barrel /Hopper Assembly (#12)
- 1 x Left Support Leg - Front (#22)
- 1 x Left Support Leg - Back (#23)
- 1 x Right Support Leg / Front (#24)
- 1 x Right Support Leg / Back (#25)
- 12 x Screw (#A)
- 12 x Washer (#B)
- 12 x Locking Washer (#C)

Installation:

- Place a piece of cardboard on the floor to prevent scratching the unit and parts during assembly. Lay the Main Barrel on its side on the cardboard, hopper end pointed upward.
- Mount the Front-Right Support Leg to the floor end of the Main Barrel using three screws, locking washers, and washers, through the three pre-drilled holes. Install screws from the inside of the Main Barrel. Repeat installation for Back-Right Support Leg. Note illustration 1A.
- Next, mount the Front-Left Support Leg to the hopper end of the Main Barrel using three screws, locking washers, and washers, through the three pre-drilled holes. Install screws from the inside of the Main Barrel. Repeat installation for Back-Left Support Leg. Note illustration 1B.

IMPORTANT: Do not tighten screws completely until bottom shelf is installed in next step.

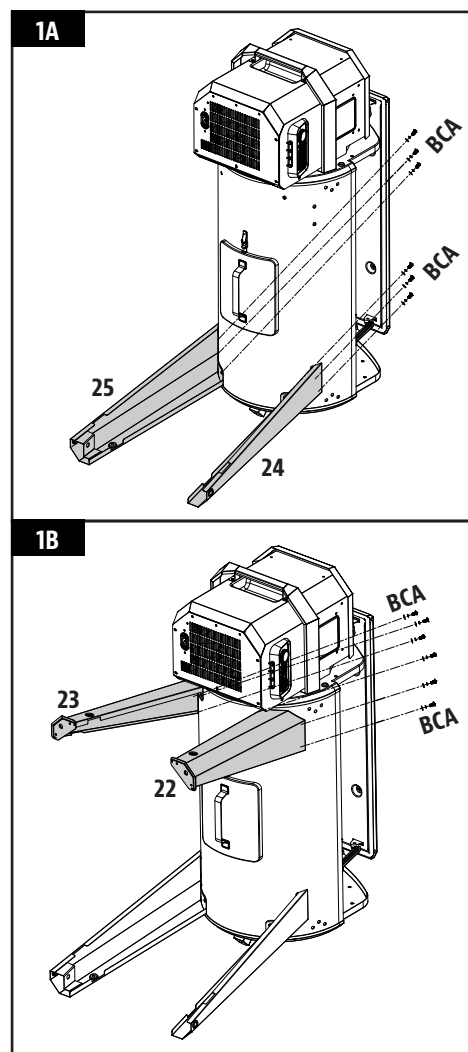

2. INSTALLING THE BOTTOM SHELF

Parts Required:

- 1 x Bottom Shelf (#26)
- 4 x Screw (#A)
- 4 x Washer (#B)
- 4 x Locking Washer (#C)

Installation:

- Mount the Bottom Shelf to each Support Leg using a screw, locking washer, and washer. Ensure the flat surface of the shelf is facing up towards the Grill Barrel.

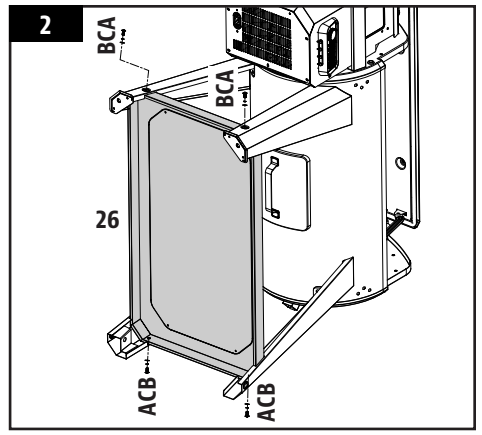

3. ADDING WHEELS TO THE CART

Parts Required:

- 2 x Locking Caster Wheels (#27)
- 2 x Wheel (#28)
- 2 x Wheel Cotter Pin (#E)
- 2 x Wheel Washer (#F)
- 2 x Wheel Axle Pin (#G)

Installation:

- Insert each Locking Caster Wheel into the bottom of each Left Support Leg by hand-tightening into the hole. Ensure that each Locking Caster Wheel is inserted completely. Note illustration 3A.
- Attach each Wheel to each Right Support Leg by inserting the Wheel Axle Pin through the Wheel, Support Leg hole, Wheel Washer, then secure using the Wheel Cotter Pin. Note illustration 3B.
- Once the shelf is secure, carefully lift the grill into an upright position.

IMPORTANT: Re-tighten the support leg screws to ensure they are completely secure after positioning the grill upright.

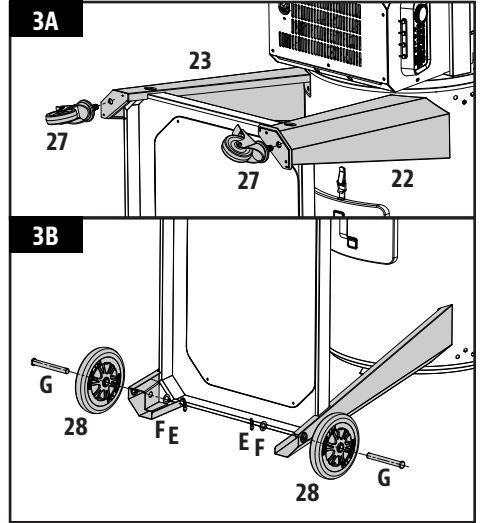

4. INSTALLING THE LID HANDLE

Parts Required:

- 1 x Lid Handle (#11)

Installation:

- Remove the pre-installed screws from the Lid Handle. From inside the barrel lid, insert one screw to protrude to the outside, then hand-tighten the screw (from the inside) into the Lid Handle. Repeat the same installation for the other end of Lid Handle.

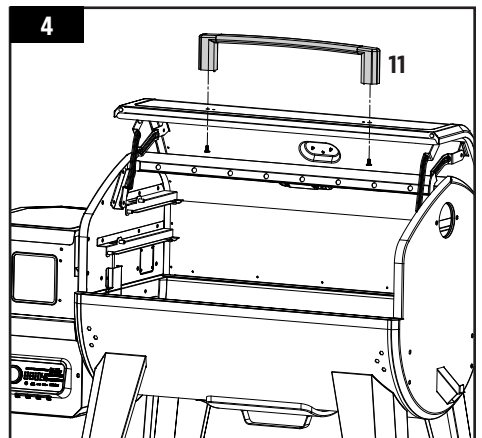

5. ASSEMBLING THE SIDE SHELF

Parts Required:

- 1 x Side Shelf (#17)
- 3 x Tool Hook (#D)

Installation:

- Turn the Side Shelf upside down. On the edge of the Side Shelf with three holes, install the tool hooks into each hole along the edge. The tool hooks will secure to the nut that is pre-mounted on the inside.

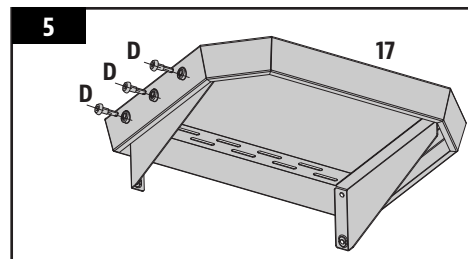

6. MOUNTING THE SIDE SHELF

Parts Required:

- 4 x Screw (#A)
- 4 x Locking Washer (#C)
- 4 x Washer (#B)

Installation:

- From underneath, fasten the Side Shelf to the side panel of the Main Barrel using four screws, locking washers, and washers.

NOTE: Do not tighten screws completely until all screws have been installed. Once all screws are installed, then tighten securely.

IMPORTANT: Avoid using the shelves to move or lift the grill. The weight of the unit will cause the shelves to break, which is not covered by warranty.

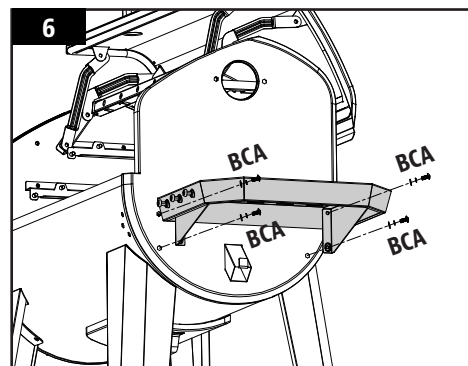

7. SECURING THE CHIMNEY

Parts Required:

- 1 x Chimney Gasket (#7)
- 1 x Chimney Cap (#8)
- 1 x Chimney Stack (#9)
- 2 x Screw (#A)
- 2 x Locking Washer (#C)
- 2 x Washer (#B)

Installation:

- Locate the chimney opening on the side of the Main Barrel. From the outside, secure the Chimney Stack and Chimney Gasket to the side panel using two screws, locking washers, and washers. The screw will fasten to the pre-mounted nut on the inside of the barrel.
- Next, secure the Chimney Cap onto the top of the Chimney Stack by rotating the Chimney Cap screw into the Chimney Stack.

NOTE: Adjust the chimney cap to affect the airflow inside the Main Grill. If cooking at low temperature, keep the cap more open. Ensure the chimney cap allows for air to escape.

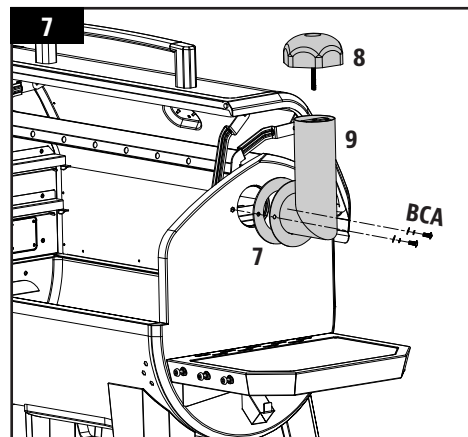

8. SECURING THE FRONT SHELF BRACKETS

Parts Required:

- 1 x Front Shelf Bracket / Left (#19)
- 1 x Front Shelf Bracket / Right (#20)
- 6 x Screw (#A)

Installation:

- Attach one Front Shelf Bracket to the front of the grill barrel by using three screws. Install each screw halfway, then tighten completely when all three screws are mounted and aligned properly.
- Repeat the same installation for the other Front Shelf Bracket.

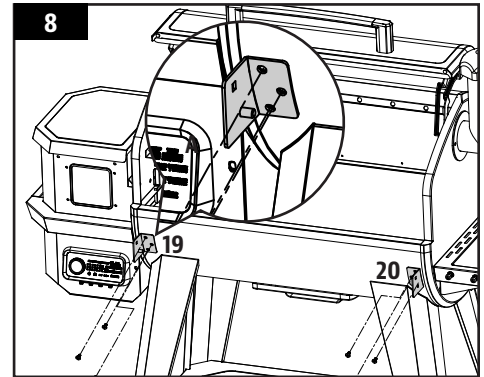

9. INSTALLING THE FRONT SHELF

Parts Required:

- 1 x Front Shelf (#21)
- 2 x Washer (#B)
- 2 x Screw (#H)
- 2 x Nut (#I)
- 2 x Bushing (#J)

Installation:

- From underneath, insert the screw (from the outside) into the Front Shelf Bracket and the Front Shelf, then add the bushing onto the screw, the washer, then the nut. Repeat installation for the other side of the Front Shelf.

NOTE: When installed correctly, the Front Shelf can be raised (for use) and lowered (for storage) with ease.

IMPORTANT: Avoid using the shelves to move or lift the grill. The weight of the unit will cause the shelves to break, which is not covered by warranty.

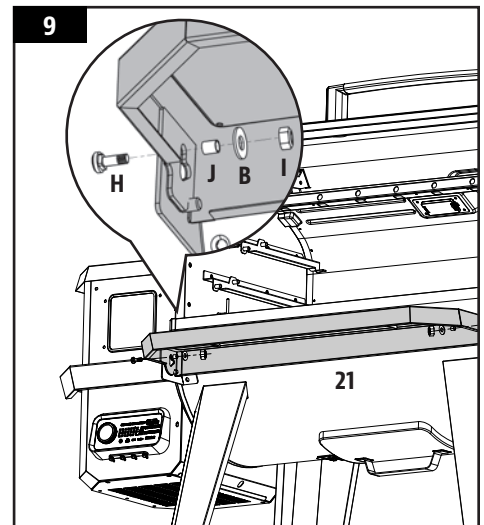

10. PLACING THE DIFFUSER PLATE

Parts Required:

- 1 x Diffuser Plate (#18)

Installation:

- Place the Diffuser plate into Main Barrel so the central opening aligns directly with the circular Burn Pot on the base of the Main Barrel.

NOTE: The Diffuser Plate does not require fastening.

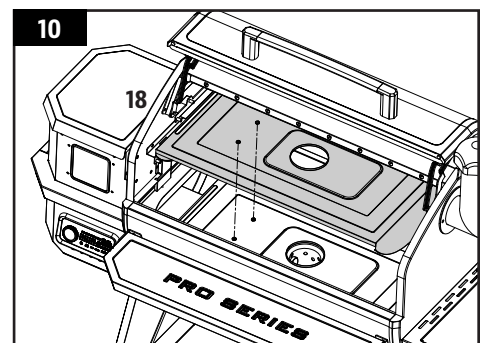

11. INSTALLING THE FLAME BROILER COMPONENTS

Parts Required:

- 1 x Flame Broiler Slider (#5)
- 1 x Flame Broiler Main Plate (#6)
- 1 x Flame Broiler Adjusting Bar Handle (#13)
- 1 x Flame Broiler Adjusting Bar (#14)

Installation:

- Insert the Flame Broiler Main Plate into the Main Grill, right side first. Rest the Flame Broiler Main Plate on the built-in ledge (on the inside right) of the Main Grill that directs grease towards the grease bucket. Slide the entire piece to the left side, and the two slots on the Flame Broiler Main Plate will fit into the rounded ledge above the Burn Pot. It will sit slightly at a downward angle. Note 11A.

IMPORTANT: If the Flame Broiler Main Plate is on the base of the barrel, it is installed incorrectly. The Flame Broiler Main Plate should sit at an angle, with the left side sitting higher than the right. Poor installation of this part may result in damage to your Main Grill barrel.

- Place the Flame Broiler Slider on top of the Flame Broiler Main Plate, covering the slotted openings. Ensure the raised tab is on the left, to easily adjust for direct or indirect flame when cooking. Note illustration 11B. Both Flame Broiler parts are lightly coated with oil to avoid rusting when shipped.
- Next, remove the Flame Broiler Adjusting Bar Handle from the Flame Broiler Adjusting Bar. Insert the Flame Broiler Adjusting Bar through the opening hole on the left side of the Main Barrel. Add the Flame Broiler Adjusting Bar Handle back onto the end outside the barrel. Next, slide the notched end of the Adjusting Bar into the locking tab on the Flame Broiler Slider, giving you adjustable access to the Flame Broiler Slider on the main plate. Note steps in 11C.

NOTE: When the Flame Broiler Slider is open and direct flame is used, do not leave the grill unattended for any period of time.

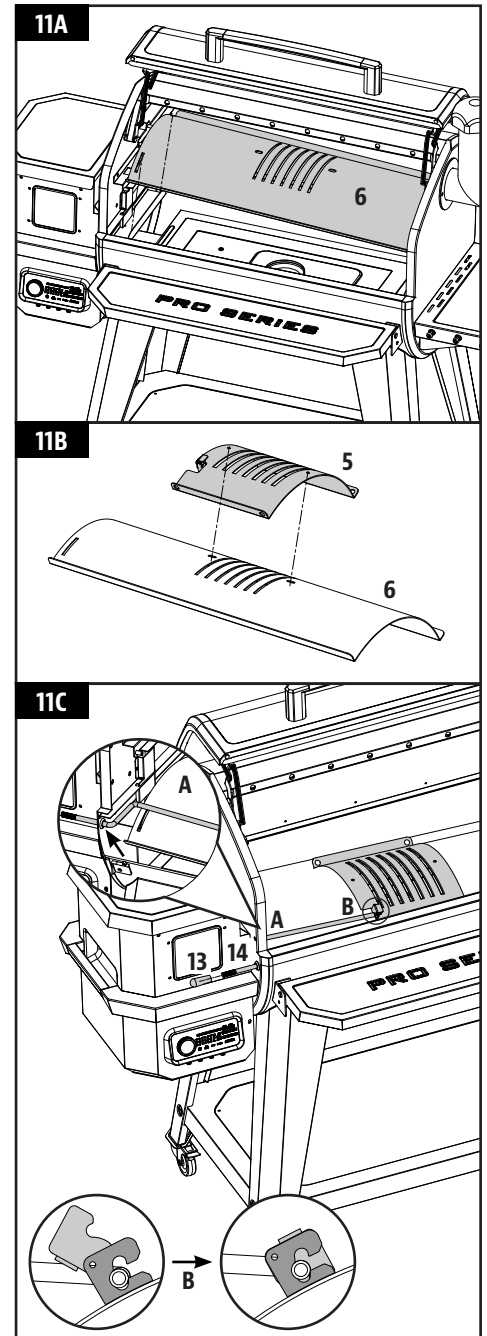

12. INSTALLING THE COOKING COMPONENTS

Parts Required:

- 1 x Top Cooking Rack (#1)
- 1 x Middle Cooking Rack (#2)
- 1 x Griddle (#3)
- 4 x Cooking Grids (#4)

Installation:

- Choose a desired main cooking surface: two Cooking Grids with the Griddle (shown in 12A) or four Cooking Grids (shown in 12B). Place the chosen combination of cooking surface on the lower grid ledges inside the Main Grill.
- Next, place the Middle Cooking Rack on the middle ledges inside the Main Grill. Place the Top Cooking Rack on the top ledges inside the Main Grill.

NOTE: To maintain the searing and grilling performance of your Cooking Grids and Cooking Racks, regular care and maintenance is required.

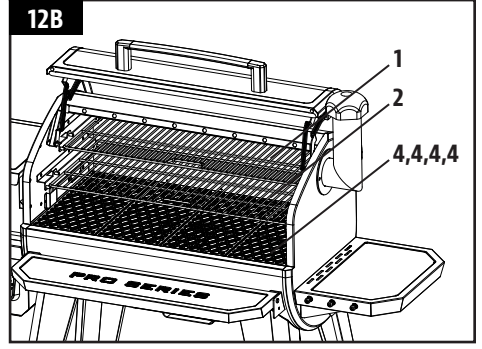
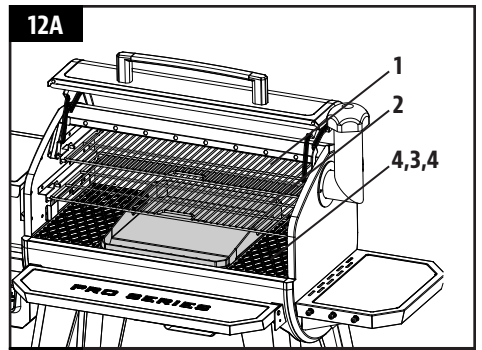

13. MOUNTING THE RACK HANGER

Parts Required:

- 1 x Rack Hanger (#10)

Installation:

- Secure the Rack Hanger to the back panel of the Main Barrel using the pre-assembly two screws. Cooking Racks can be hung on the Rack Hanger while not in use.

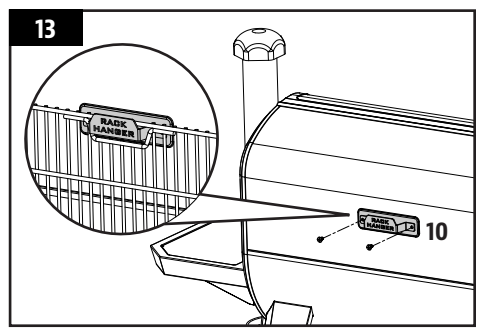

14. PLACING THE GREASE BUCKET

Parts Required:

- 1 x Grease Bucket (#16)

Installation:

- Place the Grease bucket on the spout hook on the end of the Main Barrel. Ensure it is level to avoid grease spills.
- The unit is now completely assembled.

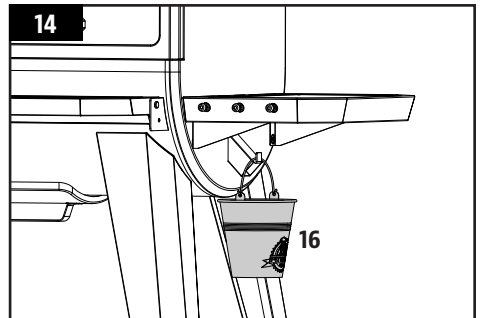

15. INSTALLING THE POWER CORD

NOTE: There are two Power Cords supplied. Select the Power Cord that is required for your region.

Parts Required:

- 1 x Power Cord Clip (#29)
- 1 x Power Cord (#30 or #31)

Installation:

- Place the Power Cord Clip on the Power Cord. Then, insert the Power Cord into the groove at the bottom of the unit. Note 15A.
- Secure the Power Clip to the bottom panel using the pre-installed screw, as shown. Note 15B.

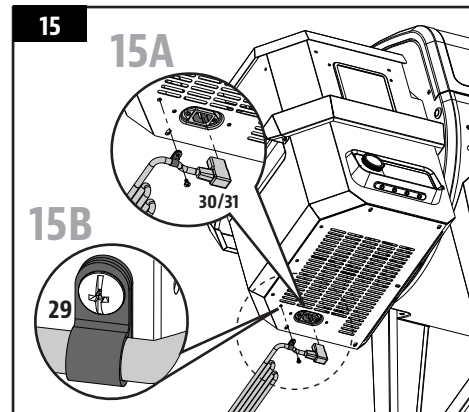

16. CONNECTING TO A POWER SOURCE

- **STANDARD OUTLET**
This appliance requires 220-240 Volt, 50 Hz, 275 W. It must be a grounded plug. Ensure grounded end is not broken off before use. The control uses a 220-240 volt, fast-blow fuse to protect the board from the ignitor.

IMPORTANT: Disconnect unit from power source when not in use.

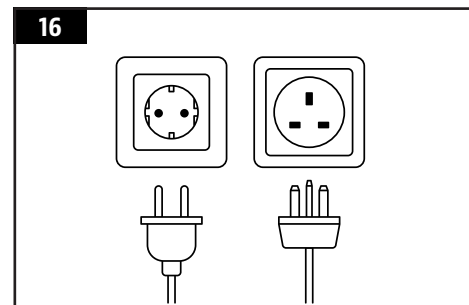

OPERATING INSTRUCTIONS

With today's lifestyle of striving to eat healthy and nutritious foods, one factor to consider is the importance of reducing fat intake. One of the best ways to cut down on fat in your diet is to use a low fat method of cooking, such as grilling. As a pellet grill uses natural wood pellets, the savory wood flavor is cooked into the meats, reducing the need for high sugar content sauces. Throughout this manual, you will notice the emphasis on grilling food slowly at LOW or MEDIUM temperature settings.

GRILL ENVIRONMENT

1. *WHERE TO SET-UP THE GRILL*

With all outdoor appliances, outside weather conditions play a big part in the performance of your grill and the cooking time needed to perfect your meals.

All Pit Boss® units should keep a minimum clearance of 914 mm (36 inches) from combustible constructions, and this clearance must be maintained while the grill is operational. This appliance must not be placed under overhead combustible ceiling or overhang. Keep your grill in an area clear from combustible materials, gasoline and other flammable vapors and liquids.

2. *COLD WEATHER COOKING*

As it becomes cooler outside, that does not mean that grilling season is over! The crisp cool air and heavenly aroma of smoked foods will help cure your winter blues.

Follow these suggestions on how to enjoy your grill throughout the cooler months:

- If smoking at low temperatures fails, increase the temperature slightly to achieve the same results.
- Organize – Get everything you require ready in the kitchen before you head outdoors. During the winter, move your grill to an area that is out of the wind and direct cold. Check local bylaws regarding the proximity of your grill in relation to your home and/or other structures. Put everything you need on a tray, bundle up tight, and get it done!
- To help keep track of the outside temperature, place an outdoor thermometer close to your cooking area. Keep a log or history of what you cooked, the outdoor temperature, and the cooking time. This will help later down the road to help you determine what to cook and how long it will take.
- In very cold weather, increase your preheating time by at least 20 minutes.
- Avoid lifting the lid any more than necessary. Cold gusts of wind can completely cool your grill temperature. Be flexible with your serving time; add extra cooking time each time you open the lid.
- Have a heated platter or a dish cover ready to keep your food warm while making the trip back inside.
- Ideal foods for winter cooking are those that require little attention, such as roasts, whole chickens, ribs, and turkey. Make your meal preparation even easier by adding simple items such as vegetables and potatoes.

3. *HOT WEATHER COOKING*

As it becomes warmer outdoors, the cooking time will decrease.

Follow these few suggestions on how to enjoy your grill throughout the hot months:

- Adjust your cooking temperatures downward. This helps to avoid unwanted flare-ups.
- Use a meat thermometer to determine the internal temperature of your foods. This helps in preventing your meat from over cooking and drying out.
- Even in hot weather it is still better to cook with the lid of your grill down.
- You can keep foods hot by wrapping them in foil, and placing them in an insulated cooler. Stuff crumpled up newspaper around the foil and this will keep food hot for 3 to 4 hours.

GRILL TEMPERATURE RANGES

Temperature readouts on the control board may not exactly match the thermometer. All temperatures listed below are approximate and are affected by the following factors: outside ambient temperature, the amount and direction of wind, the quality of pellet fuel being used, the lid being opened, and the quantity of food being cooked.

- **HIGH TEMPERATURE (205-260°C / 401-500°F)**

This range is best used to sear and grill at a high heat. Use in tandem with the Flame Broiler (slide plate) for indirect or direct flame cooking. With the **Flame Broiler open**, direct flame is used to create those "blue" steaks, as well as flame-kissed vegetables, garlic toast or s'mores! When the **Flame Broiler is closed**, the air circulates around the barrel, resulting in convection heat. High temperature is also used to preheat your grill, burn-off the cooking grids, and to achieve high heat in extreme cold weather conditions.

- **MEDIUM TEMPERATURE (135-180°C / 275-356°F)**

This range is best for baking, roasting, and finishing off that slow smoked creation. Cooking at these temperatures will greatly reduce the chances of a grease flare-up. Ensure that the Flame Broiler Slider is in the closed position, covering the slotted openings. Great range for cooking anything wrapped in bacon, or where you want versatility with control.

- **LOW TEMPERATURE (82-125°C / 180-257°F)**

This range is used to slow roast, increase smoky flavor, and to keep foods warm. Infuse more smoke flavor and keep your meats juicy by cooking longer at a lower temperature (also known as **low and slow**). Highly recommended for the big turkey at Thanksgiving, juicy ham at Easter, or the huge holiday feast.

Smoking is a variation on true barbecuing and is truly the main advantage of grilling on a wood pellet grill. **Hot smoking**, another name for **low and slow** cooking, is generally done between 82-125°C / 180-257°F. Hot smoking works best when longer cooking time is required, such as large cuts of meats, fish, or poultry.

TIP: To intensify that savory flavor, switch to a low temperature range immediately after putting your food on the grill. This allows the smoke to penetrate the meats.

The key is to experiment with the length of time you allow for smoking, before the meal is finished cooking. Some outdoor chefs prefer to smoke at the end of a cook, allowing the food to keep warm until ready to serve. Practice makes perfect!

UNDERSTANDING THE CONTROL BOARD

This P.I.D. (proportional-integral-derivative) digital Control Board is very much the same as the controls on your kitchen oven. The main advantages are the ability to automatically compensate for the different ambient conditions and fuel types.

IMPORTANT: The temperature inside of any grill will vary greatly from location to location. Even instruments calibrated together may not agree with each other.

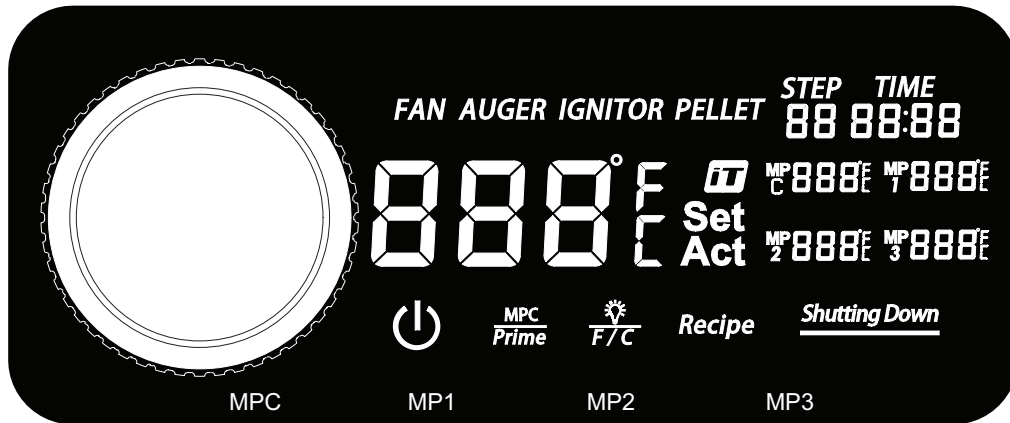

CONTROL	DESCRIPTION
	Press this button once to Power On the unit. This will begin the automatic start-up cycle. Press and hold this button for three seconds to Power-down the unit, activating the automatic cool-down cycle. The button will light up solid white when connected to a power source and when the unit is on.
	The Smoke iT® icon indicates a connectivity with Wi-Fi. When searching for a connection by Wi-Fi or via Bluetooth®, the Smoke iT® icon will blink. Once a Wi-Fi connection has been established, the Smoke iT® icon will stay solid. When connected, get live updates about the actual and set temperatures of the grill, cooking time, and meat probe temperatures. It also allows you to adjust the settings of your Control Board.
	This button has two functions: Temperature Units Switch and Light. <ol style="list-style-type: none"> 1. Quick push of this button to switch on and off the light inside the grill barrel. 2. Press and hold this button for three seconds to activate the Temperature Units Switch, changing the temperature readout. Change between Celsius (°C) and Fahrenheit (°F), as preferred. Default is set to Celsius (°C).
	This button has two functions: Meat Probe Control (MPC) and Prime Button. <ol style="list-style-type: none"> 1. The quick push of this button activates the Programmable Meat Probe - which is the first Meat Probe plug-in port (MPC). Use the Controller Knob to set the Programmable Meat Probe temperature. Press the Controller Knob again to confirm and exit the Programmable Meat Probe settings. 2. Press and hold this button for three seconds to activate a manual continuous feeding of pellets to the Burn Pot. Releasing the button will stop the manual feeding of pellets. This can be used to add more fuel to the fire before opening the barrel lid, resulting in a quick heat recovery. It can also be used while smoking, to increase the intensity of clean smoke flavor. This feature was requested from competition cookers.

	<p>The Controller Knob is used to increase, decrease, and select a setting value. Rotate the Controller Knob to select the time, temperature, or step in an active settings menu. Push the Controller Knob to confirm the chosen value.</p>
	<p>The central readout displays both the Actual and Set temperatures. The Actual temperature is constantly displayed unless the Set temperature is being adjusted. The Actual temperature is the temperature from inside the Main Barrel. The Actual temperature readout is taken by the grill probe (sensor) from the inside of the grill barrel.</p> <p>To show the Set temperature, press the Controller Knob. The Set temperature is active when the readout is blinking. To adjust the Set temperature, rotate the Controller Knob, as needed. Once the desired Set temperature is reached, press the Controller Knob to confirm the Set temperature, then the readout will return back to the Actual Temperature.</p>
<p>Recipe</p>	<p>Press the button once to activate the Recipe Steps. There are nine Recipe Steps available to set. Adjust the settings of each Recipe Step by using the Controller Knob.</p>
<p>STEP 88</p>	<p>Displays the current Recipe Step.</p>
<p>TIME 88:88</p>	<p>Displays the Time set during the Recipe Step. Press the Recipe Button to activate the Recipe settings. Use the Controller Knob to switch through the Recipe Steps, one being the Time.</p>
<p>MP C 888°F</p>	<p>Displays the Actual and Set temperature of the Programmable Meat Probe - which is the first Meat Probe plug-in port (MPC). The Actual temperature is constantly displayed unless the Set temperature is being adjusted. When the MPC Button is pressed, the selected Meat Probe readout will blink and the Set temperature can be adjusted. When not in use, disconnect the Meat Probe from the connection port and code "noP" will be displayed. Compatible with Pit Boss® Grills branded meat probes only.</p>
<p>MP 1 888°F MP 2 888°F MP 3 888°F</p>	<p>Displays the Actual temperature of a Meat Probe. These three Meat Probe readouts correspond with the plug-in connection port selected. When not in use, disconnect the Meat Probe from the connection port and code "noP" will be displayed. Compatible with Pit Boss® Grills branded meat probes only.</p>
<p>Shutting Down</p>	<p>This readout is displayed after Power-down has been selected. It indicates that the automatic cool-down cycle has started. Once the cool-down cycle is completed, the readout will no longer be visible.</p>
<p>FAN</p>	<p>The FAN icon is visible when the fan is in operation. When the central readout has the FAN icon blinking, the Fan is not working. See the section on troubleshooting for assistance.</p>
<p>AUGER</p>	<p>The AUGER icon is visible when the auger is turning. When the central readout has the AUGER icon blinking, the auger is not working. See the section on troubleshooting for assistance.</p>
<p>IGNITOR</p>	<p>The IGNITOR icon is visible when the ignitor is in use. When the central readout has the IGNITOR icon blinking, the ignitor is not working. See the section on troubleshooting for assistance.</p>
<p>PELLET</p>	<p>When the central readout has the PELLET icon visible, the fire in the Burn Pot has gone out or the hopper may be empty. See the section on troubleshooting for assistance.</p>

CONTROL BOARD FUNCTIONS

• *SETTING THE GRILL TEMPERATURE*

The Grill Probe measures the internal temperature of the Main Barrel. When the Set temperature is adjusted, the Grill Probe will read the Actual temperature inside the Main Barrel and adjust to the desired Set temperature.

IMPORTANT: The temperature of your unit is highly dependent on ambient outdoor weather, quality of pellets used, flavor of pellets, and the quantity of food being cooked.

SETTING/ADJUSTING THE SET TEMPERATURE

To adjust the desired Set temperature of the grill, follow the steps below:

1. Press the Controller Knob. This will make the Set temperature readout blink, to show it is active.
2. Use the Controller Knob again to adjust to your desired temperature.
3. Once the desired Set temperature is reached, press the Controller Knob to confirm the Set temperature, then the readout will return back to the Actual Temperature.

• *USING THE PROGRAMMABLE MEAT PROBE*

The meat probe measures the internal temperature of the meat on the grill, similar to your indoor oven. Insert the stainless-steel meat probe into the thickest portion of the meat. The internal temperature of the meat is shown on the Control Board readout. Plug-in the Meat Probe adapter to the meat probe connection port and ensure it is inserted all the way into the plug. You will feel and hear it snap in place. Not only will it cook the meat to your desired temperature, but it will automatically reduce your grill temperature to low (82°C / 180°F) to keep food warm until ready to serve. Just set it, then relax while the Meat Probe does the rest!

NOTE: When placing the meat probe into your meat, ensure the meat probe and meat probe wires avoid direct contact with flame or excess heat. This can result in damage to your meat probe. Run the excess wire out the rear exhaust holes of the Main Barrel, the top of the Main Barrel (near the grill lid hinge), or through the front hole near the hopper. When not in use, disconnect from the meat probe connection port, and place in the holes on the hopper handle to keep protected and clean.

SETTING/ADJUSTING THE PROGRAMMABLE MEAT PROBE

To program the desired Set temperature of the Programmable Meat Probe, follow the steps below:

1. Quick press the MPC button to activate the Programmable Meat Probe. When active, the temperature readout of the Meat Probe will blink.
2. Use the Controller Knob to adjust to the desired Set temperature.
3. Once the desired Set temperature of your selected Meat Probe is reached, press the Controller Knob again to confirm and exit the Programmable Meat Probe settings.

• *SETTING UP A RECIPE*

The Recipe function allows the user to program cooking instructions, known as Recipe Steps, for the Control Board to follow and automatically run. These cooking instructions are a combination between Cooking temperature and Time. Starting from the first Recipe Steps (01), the Control Board will cycle through each Recipe Steps to cook the meal. When all the Recipe Steps are complete, the Control Board will automatically switch to a low temperature of 82°C / 180°F so that the meal stays warm until ready to serve. There are a total of nine Recipe Steps available to be programmed.

HOW TO PROGRAM A RECIPE STEP

To set one or more of the Recipe Steps, follow the steps below:

1. Press and hold the Recipe Button. This will make the Recipe Button blink to show the Recipe settings are active. This will also activate the Recipe Steps and the letter 'S' will be on to show it is active.
 - Use the Controller Knob to select the Recipe Step. Start with the first Recipe Step (01).
 - When desired Recipe Step is reached, press the Controller Knob to go to next setting.
 2. Set the Time hours. The hours of the Time readout will blink, to show it is selected.
 - Use the Controller Knob to select the hours desired.
 - When desired hours are reached, press the Controller Knob to go to next setting.
 3. Set the Time minutes. The minutes of the Time readout will blink, to show it is selected.
 - Use the Controller Knob to select the minutes desired.
 - When desired minutes are reached, press the Controller Knob to go to next setting.
 4. Set the Temperature. The central temperature readout will blink, to show it is selected.
 - Use the Controller Knob to select the desired temperature.
 - When desired temperature is reached, press and hold the Recipe Button to lock in all Recipe settings for that Recipe Step.
 - To set another Recipe Step, quick press the Recipe Button to select another Recipe Step, programming a multiple Recipe Step cook. Repeat steps above, as desired.
- Or,
- Press and hold the Recipe Button a second time to exit the Recipe settings and run the Recipe. The Recipe Button will stop blinking.

NOTE: The Recipe Steps will reset when the unit is shut-down / turned off.

CONNECTING TO THE SMOKE IT® APP

Follow these instructions on how to connect your grill to the Smoke iT® app with your Android™ or iOS® device. The app will allow you to control and monitor your grill and meat probe temperatures from your mobile device. Enjoy the benefits that Smoke IT® mobile connectivity has to offer!

1. Download the Smoke iT® app. Open the app and allow Bluetooth® to be enabled for setup. New users will need to create an account and follow the prompts to login.
2. If you are within Bluetooth® range (9 m / 30 ft), the Smoke iT® app will automatically detect your grill. Select your grill model. If you do not see your grill on the screen, ensure your unit is connected to a power source and is turned on.
3. Name your grill model (ie. My Smoker) in the app and select "Connect" at the bottom of the screen. This will save your grill model in the devices menu.
4. From the devices menu, click the grill model to connect. This will show you the control board screen.
5. Click the settings option (gear) in the top-right corner, enter your Wi-Fi credentials, then click the check mark at the bottom of the screen to connect. Now both Bluetooth® and Wi-Fi (cloud) icons will show on the devices menu, showing that the grill is connected.

While using the app, the screen will shine bright when the grill is active and connected. If the app screen or grill goes dark on the devices menu, check your wireless connection or power source.

HOPPER PRIMING PROCEDURE

These instructions should be followed the first time the grill is ignited, and each time the grill runs out of pellets in the hopper. The auger must be primed to allow pellets to travel through the length of the auger, and fill the feed system. **If not primed, the ignitor will timeout before the pellets are ignited, and no fire will start.** Follow these steps to prime the hopper:

1. Open the Main Barrel lid. Remove all cooking components from the interior of the grill. Locate the Burn Pot in the bottom of the Main Barrel. Check the Burn Pot to ensure there is no obstruction for proper ignition.
2. Plug the power cord into a power source. Press the Power button to Power On the unit. Check the following items:
 - That you can hear the auger turning. Place your hand above the Burn Pot and feel for air movement. Do not place your hand or fingers inside the Burn Pot. This can cause injury.
 - After approximately a minute, you should smell the ignitor burning and begin to feel the air getting warmer in the Burn Pot. The ignitor tip does not glow red, but gets extremely hot and will burn. Do not touch the ignitor.
3. Once verified that all electric components are working correctly, press the Power Button to turn the unit off.
4. Open the hopper lid. Ensure there are no foreign objects in the hopper or auger feed system. Fill the hopper with dry, all natural barbecue hardwood pellets.
5. Press the Power Button to turn the unit on again. The grill start-up cycle has a preset temperature of 176°C / 350°F, so it will begin to heat up. Press and hold the Prime Button until you see pellets on the inside of the grill from the auger tube. Once pellets begin to drop into the Burn Pot, release the Prime Button.
6. Press the Power Button to turn the unit off.
7. Re-install the cooking components into the Main Barrel. The grill is now ready to use.

FIRST USE – GRILL BURN-OFF

Once your hopper has been primed and before cooking on your grill for the first time, it is important to complete a grill burn-off. Start the grill and operate at any temperature over 176°C / 350°F (with the lid down) for 30 to 40 minutes to burn-off the grill and rid it of any foreign matter.

AUTOMATIC START-UP PROCEDURE

1. Plug the power cord into a grounded power source. Open the Main Barrel lid. Check the Burn Pot to ensure there is no obstruction for proper ignition. Open the hopper lid. Ensure there are no foreign objects in the hopper or auger feed system. Fill the hopper with dry, all natural barbecue hardwood pellets.
2. Press the Power Button to turn the unit on. This will activate the start-up cycle. The auger feed system will begin to turn, the ignitor will begin to glow and the fan will supply air to the Burn Pot. The grill will begin to produce smoke while the start-up cycle is taking place. The barrel lid must remain open during the start-up cycle. To confirm the start-up cycle has begun properly, listen for a torchy roar, and notice some heat being produced.
3. Once the heavy, white smoke has dissipated, the start-up cycle is complete and you are ready to enjoy your grill at your desired temperature!

SHUTTING OFF YOUR GRILL

1. When finished cooking, with the Main Barrel lid remaining closed, press and hold the the Power Button for three seconds to Power-down the unit. The grill will begin its automatic cool-down cycle. The auger system will stop feeding fuel, the flame will burn out, and the fan will continue to run until the cool-down cycle is complete.

CARE AND MAINTENANCE

WARNING: Always disconnect the electrical cord prior to opening the grill for any inspection, cleaning, maintenance or service work. Ensure the grill is completely cooled to avoid injury.

Any Pit Boss® unit will give you many years of flavorful service with minimum cleaning. Follow these cleaning and maintenance tips to service your grill:

1. ASH CLEAN-OUT

- At the bottom of the grill barrel is an ash cleanout feature, giving you easy access to the inside of your fire box to easily clean it as often as needed. To empty, release the buckle latch on the ash box hook. While holding the handle, slide the ash box away from the buckle, then pull down to remove. Once emptied, replace the ash box by lifting it back into the bottom of the grill barrel, sliding the ash box towards the buckle, then fastening the ash box hook with the buckle latch.

WARNING: This feature can only be operated when the grill is cooled down.

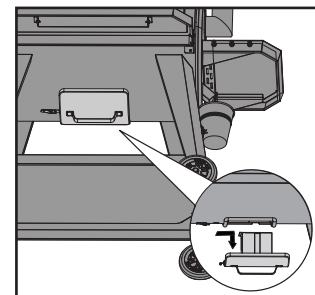

2. HOPPER ASSEMBLY

- Running all pellets out of your auger system is recommended if your grill will be unused for an extended period of time. This can be done by simply running your grill, on an empty hopper, until all pellets have emptied from the auger tube.
- Check and clean off any debris from the fan air intake vent, found on the bottom of the hopper. Once the hopper access panel is removed (see **Electric Wire Diagram** for diagram), carefully wipe off any grease build-up directly on the fan blades. This ensures airflow is sufficient to the feed system.

HOPPER CLEAN-OUT FEATURE

The hopper includes a clean-out feature to allow for easy cleaning and the ability to change out wood pellet fuel flavors. To empty, follow these steps:

- Locate the clean-out door and door hook on the back side of the hopper.
- Rotate the door hook (at the top) to the right so it is detached from the release latch rod. Place a clean, empty pail under the clean-out door and allow the door to lower. Lift the release latch rod to open the drop-chute plate, allowing the pellets from the hopper to empty.
- Once empty, push the drop-chute plate back up into place by hand. It will lock into place. Close the clean-out door and rotate the door hook back onto the release latch rod to secure.

NOTE: Use a long handled brush or shop-vac to remove excess pellets, sawdust, and debris for a complete clean-out through the hopper screen.

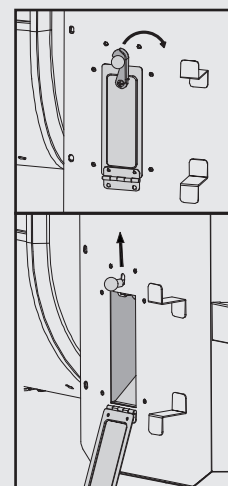

3. PROBES

- Kinks or folds in the probe wires may cause damage. A meat probe not in use should be rolled up in a large, loose coil.
- Although both the grill probe and the meat probes are stainless steel, do not place in the dishwasher or submerge in water. Water damage to the internal wires will cause a probe to short-out, causing false readings. If a probe is damaged, it should be replaced.

4. **INSIDE SURFACES**

- It is recommended to clean your Burn Pot after every few uses. This will ensure proper ignition and avoid any hard build-up of debris or ash in the Burn Pot.
- Use a long-handled grill cleaning brush, remove any food or build-up from the cooking grids. Best practice is to do this while they are still warm from a previous cook. Grease fires are caused by too much fallen debris on the cooking components of the grill. Clean the inside of your grill on a consistent basis. In the event you experience a grease fire, keep the grill lid closed to choke out the fire. If the fire does not go out quickly, carefully remove the food, turn the grill off, and shut the lid until the fire is completely out. Lightly sprinkle baking soda, if available.
- Check your grease bucket often, and clean out as necessary. Keep in mind the type of cooking you do.

IMPORTANT: Due to high heat, do not cover the Flame Broiler or probes with aluminum foil.

5. **OUTSIDE SURFACES**

- The front shelf includes a removable panel underneath for ease of cleaning. From below, push the backing plate towards the Main Barrel to remove. Clean, then replace by sliding back into place.
- Wipe your grill down after each use. Use warm soapy water to cut the grease. Do not use oven cleaner, abrasive cleansers or abrasive cleaning pads on the outside grill surfaces. **All painted surfaces are not covered under warranty, but rather are part of general maintenance and upkeep.** For paint scratches, wearing, or flaking of the finish, all painted surfaces can be touched up using high heat BBQ paint.
- Use a grill cover to protect your grill for complete protection! A cover is your best protection against weather and outside pollutants. When not in use or for longterm storage, keep the unit under a cover in a garage or shed.

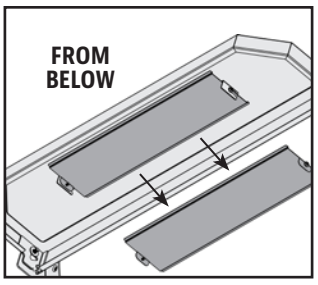

CLEANING FREQUENCY TIME TABLE (NORMAL USE)

ITEM	CLEANING FREQUENCY	CLEANING METHOD
Bottom of Main Grill	Every 5-6 Grill Sessions	Scoop Out, Shop-Vac Excess Debris
Burn Pot	Every 2-3 Grill Sessions	Scoop Out, Shop-Vac Excess Debris
Cooking Grids	After Each Grill Session	Burn Off Excess, Brass Wire Brush
Flame Broiler	Every 5-6 Grill Sessions	Scrape Main Plate with Slider, Do Not Wash Clean
Shelves	After Each Grill Session	Scrub Pad & Soapy Water
Grease Bucket	After Each Grill Session	Scrub Pad & Soapy Water
Auger Feed System	When Pellet Bag is Empty	Allow Auger to Push Out Sawdust, Leaving Hopper Empty
Hopper Electric Components	Once A Year	Dust Out Interior, Wipe Fan Blades with Soapy Water
Air Intake Vent	Every 5-6 Grill Sessions	Dust, Scrub Pad & Soapy Water
Grill Probe	Every 2-3 Grill Sessions	Scrub Pad & Soapy Water

TIPS & TECHNIQUES

Follow these helpful tips and techniques, passed on from Pit Boss® owners, our staff, and customers just like you, to become more familiar with your grill:

1. *FOOD SAFETY*

- Keep everything in the kitchen and cooking area clean. Use different platters and utensils for the cooked meat than the ones you used to prepare or transport the raw meat out to the grill. This will prevent cross contamination of bacteria. Each marinade or basting sauce should have its own utensil.
- Keep hot foods hot (above 60°C / 140°F), and keep cold foods cold (below 3°C / 37°F).
- A marinade should never be saved to use at a later time. If you are going to use it to serve with your meat, be sure to bring it to a boil before serving.
- Cooked foods should not be left out in the heat for more than an hour. Do not leave hot foods out of refrigeration for more than two hours.
- Defrost and marinate meats by refrigeration. Do not thaw meat at room temperature or on a counter top. Bacteria can grow and multiply rapidly in warm, moist foods. Wash hands thoroughly with hot, soapy water before starting any meal preparation and after handling fresh meat, fish and poultry.

2. *COOKING PREPARATION*

- Be prepared, or ***Mise en Place***. This refers to preparing the cooking recipe, fuel, accessories, utensils, and all ingredients you require at grill side before you start cooking. Also, read the entire recipe, start to finish, before lighting the grill.
- A BBQ floor mat is very useful. Due to food handling accidents and cooking spatter, a BBQ floor mat would protect a deck, patio, or stone platform from the possibility of grease stains or accidental spills.

3. *GRILLING TIPS AND TECHNIQUES*

- To infuse more smoke flavor into your meats, cook longer and at lower temperatures (also known as ***low and slow***). Meat will close its fibers after it reaches an internal temperature of 49°C / 120°F. Misting, or mopping, are great ways to keep meat from drying out.
- While searing your meats, cook with the lid down. Always use a meat thermometer to determine the internal temperature of the foods you are cooking. Smoking foods with hardwood pellets will turn meats and poultry pink. The band of pink (after cooking) is referred to as a ***smoke ring*** and is highly prized by outdoor chefs.
- Sugar-based sauces are best applied near the end of cooking to prevent burning and flare-ups.
- Leave open space between the foods and the extremities of the barrel for proper heat flow. Food on a crowded grill will require more cooking time.
- Use a set of long-handled tongs for turning meats, and a spatula for turning burgers and fish. Using a piercing utensil, such as a fork, will prick the meat and allow the juices to escape.
- Foods in deep casserole dishes will require more time to cook than a shallow baking pan.
- It's a good idea to put cooked food onto a heated platter, keeping the food warm. Red meats, such as steak and roasts, benefit from resting for several minutes before serving. It allows the juices that were driven to the surface by heat to ease back to the center of the meat, adding more flavor.

TROUBLESHOOTING

Proper cleaning, maintenance and the use of clean, dry, quality fuel will prevent common operational problems. When your Pit Boss® grill is operating poorly, or on a less frequent basis, the following troubleshooting tips may be helpful. For FAQ, please visit www.pitboss-grills.com. You may also contact your local Pit Boss® authorized dealer or contact Customer Service for assistance.

WARNING: Always disconnect the electrical cord prior to opening the grill for any inspection, cleaning, maintenance or service work. Ensure the grill is completely cooled to avoid injury.

PROBLEM	CAUSE	SOLUTION
No Power Lights On The Control Board	Not Connected To Power Source	Ensure unit is plugged into a working power source. Reset breaker. Ensure GFCI is a minimum 10 Amp service (see Electric Wire Diagram for access to electric components) Ensure all wire connections are firmly connected and dry.
	Fuse Blown On The Control Board	Remove hopper access panel (see Electric Wire Diagram for diagram), press in plastic tabs holding the control board in place and carefully pull controller inside the hopper to release controller. Check the fuse for a broken wire or if the wire has turned black. If yes, fuse needs to be manually replaced.
	Faulty Control Board	Control Board needs to be replaced. Contact Customer Service for a replacement part.
Fire in Burn Pot Will Not Light	Auger Not Primed	Before the unit is used for the first time or anytime the hopper is completely emptied out, the auger must be primed to allow pellets to fill the auger tube. If not primed, the ignitor will timeout before the pellets reach the Burn Pot. Follow Hopper Priming Procedure .
	Auger Motor Is Jammed	Remove cooking components from the Main Barrel. Press the Power Button to turn the unit on and inspect the auger feed system. Visually confirm that the auger is dropping pellets into the Burn Pot. If not operating properly, call Customer Service for assistance or a replacement part.
	Ignitor Failure	Remove cooking components from the Main Barrel. Press the Power Button to turn the unit on and inspect the ignitor. Visually confirm that the ignitor is working by placing your hand above the Burn Pot and feeling for heat. Visually confirm that the ignitor is protruding approximately 13mm / 0.5 inches in the Burn Pot. If not operating properly, call Customer Service for assistance or a replacement part.
Readout of actual temperature will not adjust	Grill probe dirty	Follow care and maintenance instructions.
	Grill probe is broken	Grill probe needs to be replaced. Contact customer service.
Grill Will Not Achieve Or Maintain Stable Temperature	Insufficient Air Flow Through Burn Pot	Check Burn Pot for ash build-up or obstructions. Follow Care and Maintenance instructions for ash build-up. Check fan. Ensure it is working properly and air intake is not blocked. Follow Care and Maintenance instructions if dirty. Check auger motor to confirm operation, and ensure there is no blockage in the auger tube. Once all the above steps have been done, start the grill, set temperature to SMOKE and wait for 10 minutes. Check that the flame produced is bright and vibrant.
	Lack Of Fuel, Poor Fuel Quality, Obstruction In Feed System	Check hopper to check that fuel level is sufficient, and replenish if low. Should the quality of wood pellets be poor, or the length of the pellets too long, this may cause an obstruction in the feed system. Remove pellets and follow Care and Maintenance instructions.
	Grill Probe	Check status of grill probe. Follow Care and Maintenance instructions if dirty. Contact Customer Service for a replacement part if damaged.
Grill Produces Excess Or Discolored Smoke	Grease Build-Up	Follow Care and Maintenance instructions.
	Wood Pellet Quality	Remove moist wood pellets from hopper. Follow Care and Maintenance instructions to clean out. Replace with dry wood pellets.
	Burn Pot Is Blocked	Clear Burn Pot for moist wood pellets. Follow Hopper Priming Procedure .
	Insufficient Air Intake For Fan	Check fan. Ensure it is working properly and air intake is not blocked. Follow Care and Maintenance instructions if dirty.

Frequent Flare-Ups	Cooking Temperature	Attempt cooking at a lower temperature. Grease does have a flash point. Keep the temperature under 176°C / 350°F when cooking highly greasy food.
	Grease Build-Up On Cooking Components	Follow Care and Maintenance instructions.
ErP Error Code	Unit Not Turned Off Properly When Last Connected To Power	Safety feature prevents an automatic restart. Press the Power Button to turn the unit off, wait two minutes, then press the Power Button to turn the unit on again. Turn to desired temperature. If error code still displayed, contact Customer Service.
	Power Outage While Unit In Operation	
ErH Error Code	The Unit Has Overheated, Possibly Due To Grease Fire Or Excess Fuel	Press the Power Button to turn the unit off, and allow grill to cool. Follow Care and Maintenance instructions. After maintenance, remove pellets, and confirm positioning of all component parts. Once cooled, press the Power Button to turn the unit on, then select desired temperature. If error code still displayed, contact Customer Service.
ErL Error Code	Grill fails to perform start-up cycle	Check proper positioning of cooking components. Check hopper for sufficient fuel or if there is an obstruction in the feed system. Remove pellets and follow Care and Maintenance instructions. Check grill probe. Confirm if actual temperature is correct and accurate. Follow Care and Maintenance instructions if dirty. Check ignitor positioning and that it is heating up properly. In extreme cold, the grill may require a second start. Turn grill off, wait, then turn on again. Check fan. Ensure it is working properly. Follow Care and Maintenance instructions if dirty.
	Grill will not stay lit	
PELLET Error Code Blinking	Lack Of Fuel, Poor Fuel Quality, Obstruction In Feed System, Jammed Auger	Check hopper to check that fuel level is sufficient and replenish if low. Should the quality of wood pellets be poor, or the length of the pellets too long, this may cause an obstruction in the feed system. Remove pellets and follow Care and Maintenance instructions.
IGNITOR Error Code Blinking	Ignitor is not working properly, not making a connection	Remove cooking components from the Main Barrel. Press the Power Button to turn the unit on and inspect the igniter. Visually confirm that the igniter is working by placing your hand above the burn grate and feeling for heat. Visually confirm that the igniter is aligned with the hole in the burn grate, and open to light the pellets. If not operating properly, call Customer Service for assistance or a replacement part.
	Ignitor failure	Igniter needs to be replaced. Contact Customer Service for replacement part.
AUGER Error Code Blinking	Auger not primed	Before the unit is used for the first time or anytime the hopper is completely emptied out, the auger must be primed to allow pellets to fill the feed system. If not primed, the igniter will timeout before the pellets ignite. Follow Hopper Priming Procedure .
	Auger motor is jammed, not making connection	Remove cooking components from the Main Barrel. Press the Power Button to turn the unit on and inspect the auger feed system. Visually confirm that the auger is dropping pellets into the burn pot. If not operating properly, call Customer Service for assistance or a replacement part.
FAN Error Code Blinking	Fan is not working properly, not making a connection	Check fan. Ensure it is working properly and air intake is not blocked. Remove hopper access panel (see Electric Wire Diagram for diagram), and check for any damage to the fan wires. Follow Care and Maintenance instructions if fan blades are dirty.

ELECTRICAL WIRE DIAGRAM

The Digital Control Board system is an intricate and valuable piece of technology. For protection from power surges and electrical shorts, consult the wire diagram below to ensure your power source is sufficient for the operation of the unit.

PB – ELECTRIC REQUIREMENTS
220-240 V, 50 Hz, 275 W, 3-PRONG GROUNDED PLUG

NOTE: Electrical components, passed by product safety testing and certification services, comply with a testing tolerance of $\pm 5-10$ percent.

LOCATE AND REMOVE THE EIGHT SCREWS OF ACCESS PANEL ON UNDERSIDE OF UNIT

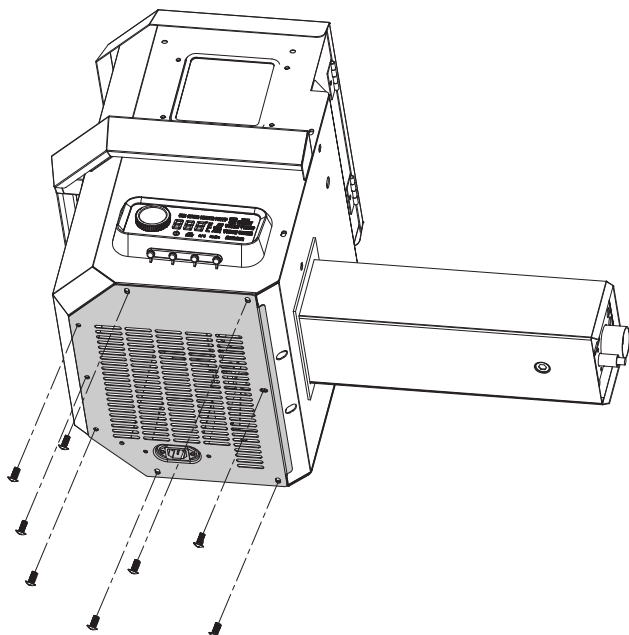

FUEL INPUT RATING:
 2.0 KG/H
 (4.4 LB/H)

CONTROL BOARD

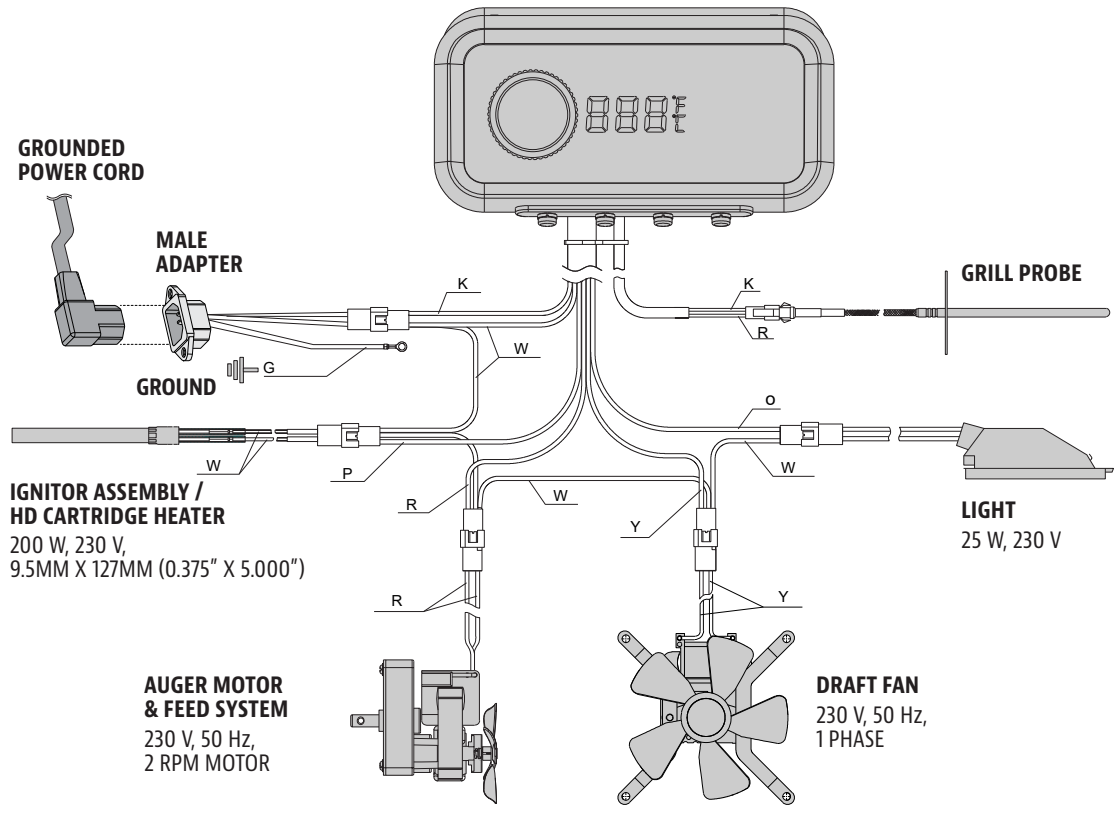

- INDEX**
- K : BLACK
 - W : WHITE
 - R : RED
 - Y : YELLOW
 - P : PURPLE
 - O : ORANGE
 - G : GREEN

IGNITOR ASSEMBLY / HD CARTRIDGE HEATER
 200 W, 230 V,
 9.5MM X 127MM (0.375" X 5.000")

AUGER MOTOR & FEED SYSTEM
 230 V, 50 Hz,
 2 RPM MOTOR

DRAFT FAN
 230 V, 50 Hz,
 1 PHASE

GRILL REPLACEMENT PARTS

Part#	Description
1	Top Cooking Rack (x1)
2	Middle Cooking Rack (x1)
3	Griddle (x1)
4	Cooking Grids (x4)
5	Flame Broiler Slider (x1)
6	Flame Broiler Main Plate (x1)
7	Chimney Gasket (x1)
8	Chimney Cap (x1)
9	Chimney Stack (x1)
10	Rack Hanger (x1)
11	Lid Handle (x1)
12	Flame Broiler Adjusting Bar Handle (x1)
13	Flame Broiler Adjusting Bar (x1)
14	Hopper Assembly (x1)
15	Main Barrel (x1)
16	Meat Probe (x2)
17	Ash Box (x1)
18	Ash Box Gasket (x1)
19	Grease Bucket (x1)
20	Side Shelf (x1)
21	Diffuser Plate (x1)
22	Front Shelf Bracket / Left (x1)
23	Front Shelf Bracket / Right (x1)
24	Front Shelf (x1)
25	Left Support Leg - Front (x1)
26	Left Support Leg - Back (x1)
27	Right Support Leg - Front (x1)
28	Right Support Leg - Back (x1)
29	Bottom Shelf (x1)
30	Locking Caster Wheels (x2)
31	Wheel (x2)
A	Screw (x28)
B	Washer (x24)
C	Locking Washer (x22)
D	Tool Hook (x3)
E	Wheel Cotter Pin (x2)
F	Wheel Washer (x2)
G	Wheel Axle Pin (x2)
H	Screw (x2)
I	Nut (x2)
J	Bushing (x2)

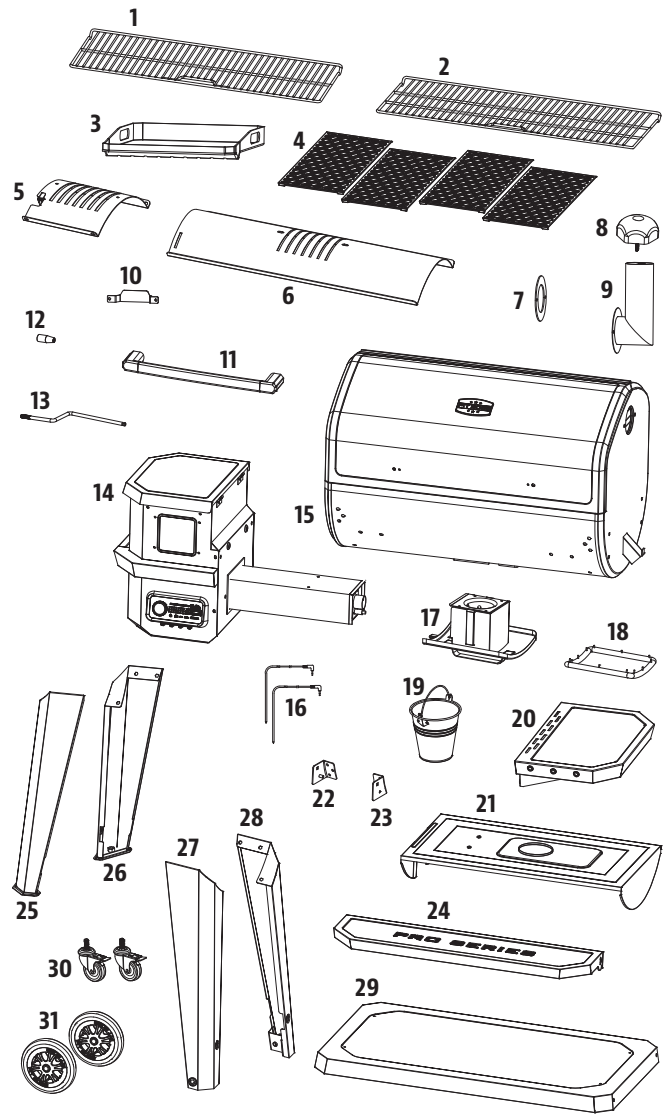

NOTE: Due to ongoing product development, parts are subject to change without notice.

HOPPER REPLACEMENT PARTS

Part#	Description
1	Hopper Lid (x1)
2	Hopper Safety Screen (x1)
3	Hopper Box Housing (x1)
4	Hopper Handle (x1)
5	Drop Chute Locker Handle (x1)
6	Drop Chute Assembly (x1)
7	Drop Chute Door (x1)
8	Auger Motor (x1)
9	Nylon Bushing (x1)
10	Auger Flighting Assembly (x1)
11	Auger Box Housing (x1)
12	Hopper Housing Gasket (x1)
13	Ash Box (x1)
14	Burn Pot (x1)
15	Combustion Fan (x1)
16	Ignitor (x1)
17	Hopper Access Panel (x1)
18	Power Cord Waterproof Cover (x1)
19	Power Cord Clip (x1)
20	Power Cord - F Plug (x1)
21	Power Cord - G Plug (x1)
22	Control Board (x1)

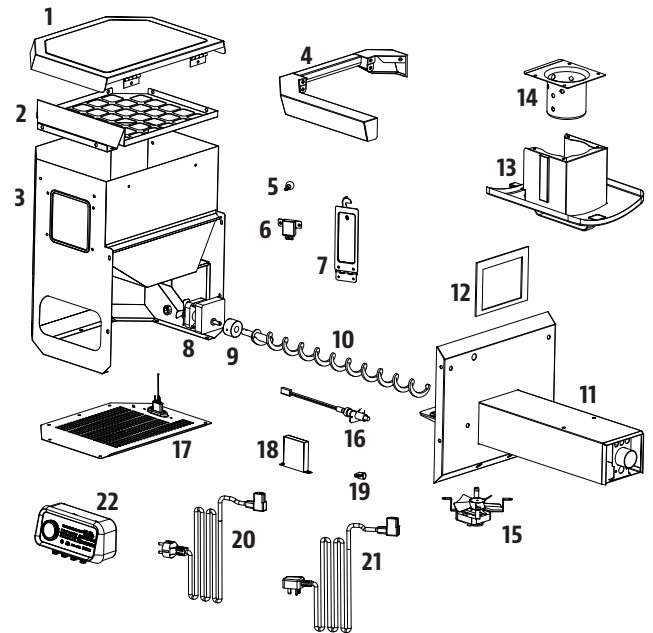

WARRANTY

CONDITIONS

All wood pellet grills by Pit Boss®, manufactured by Dansons, carry a limited warranty from the date of sale by the original owner. The warranty coverage begins on the original date of purchase and proof of date of purchase, or copy of original bill of sale, is required to validate the warranty. Customers will be subject to parts, shipping, and handling fees if unable to provide proof of the purchase or after the warranty has expired. Dansons carries a five (5) year warranty against defects and workmanship on all parts, and five (5) years on electrical components. Dansons warrants that all part(s) are free of defects in material and workmanship, for the length of use and ownership of the original purchaser. Warranty does not cover damage from wear and tear, such as scratches, dents, dings, chips or minor cosmetic cracks. These aesthetic changes of the grill do not affect its performance. Repair or replacement of any part does not extend past the limited warranty beyond the five (5) years from date of purchase.

During the term of the warranty, Dansons' obligation shall be limited to furnishing a replacement for defective and/or failed components. As long as it is within the warranty period, Dansons' will not charge for repair or replacement for parts returned, freight prepaid, if the part(s) are found by Dansons' to be defective upon examination. Dansons' shall not be liable for transportation charges, labor costs, or export duties. Except as provided in these conditions of warranty, repair or replacement of parts in the manner and for the period of time mentioned heretofore shall constitute the fulfillment of all direct and derivate liabilities and obligations from Dansons to you.

Dansons takes every precaution to utilize materials that retard rust. Even with these safeguards, the protective coatings can be compromised by various substances and conditions beyond Dansons' control. High temperatures, excessive humidity, chlorine, industrial fumes, fertilizers, lawn pesticides and salt are some of the substances that can affect metal coatings. For these reasons, the warranty does not cover rust or oxidization, unless there is loss of structural integrity on the grill component. Should any of the above occur, kindly refer to the care and maintenance section to prolong the lifespan of your unit. Dansons recommends the use of a grill cover when the grill is not in use. This warranty is based on normal domestic use and service of the grill and neither limited warranty coverage's apply for a grill which is used in commercial applications.

EXCEPTIONS

There is no written or implied performance warranty on Pit Boss® grills, as the manufacturer has no control over the installation, operation, cleaning, maintenance or the type of fuel burned. This warranty will not apply nor will Dansons assume responsibility if your appliance has not been installed, operated, cleaned and maintained in strict accordance with this owner's manual. Any use of gas not outlined in this manual may void the warranty. The warranty does not cover damage or breakage due to misuse, improper handling or modifications. Neither Dansons, or authorized Pit Boss® dealer, accepts responsibility, legal or otherwise, for the incidental or consequential damage to the property or persons resulting from the use of this product. Whether a claim is made against Dansons based on the breach of this warranty or any other type of warranty expressed or implied by law, the manufacturer shall in no event be liable for any special, indirect, consequential or other damages of any nature whatsoever in excess of the original purchase of this product. All warranties by manufacturer are set forth herein and no claim shall be made against manufacturer on any warranty or representation. Some states do not allow the exclusion or limitation of incidental or consequential damages, or limitations of implied warranties, so the limitations or exclusions set forth in this limited warranty may not apply to you. This limited warranty gives you specific legal rights and you may have other rights, which vary from state to state.

ORDERING REPLACEMENT PARTS

To order replacement parts, please contact your local Pit Boss® dealer or visit our online store at: www.pitboss-grills.com

CONTACT CUSTOMER SERVICE

If you have any questions or problems, contact Customer Service, Monday through Sunday, 4am - 8pm PST (EN/FR/ES).

service@pitboss-grills.com | Toll-Free: 1-877-303-3134 | Toll-Free Fax: 1-877-303-3135

WARRANTY SERVICE

Contact your nearest Pit Boss® dealer for repair or replacement parts. Dansons requires proof of purchase to establish a warranty claim; therefore, retain your original sales receipt or invoice for future reference. The serial and model number of your Pit Boss® can be found inside the lid of the hopper. Record numbers below as the label may become worn or illegible.

MODEL

SERIAL NUMBER

DATE OF PURCHASE

AUTHORIZED DEALER